



DIOSURE1200

1200W / 10-100MS / No limitation within 1 year

Super High Power

Super Long Life Span

Super Short pulse Duration

755nm 808nm 940nm 1064nm

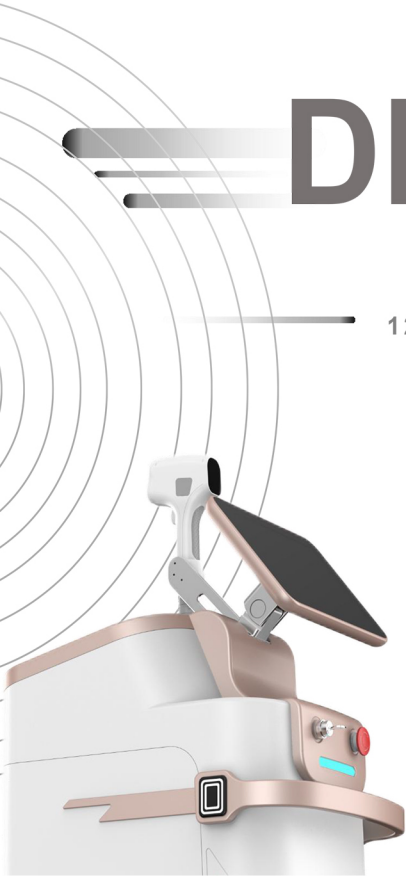

Advantages

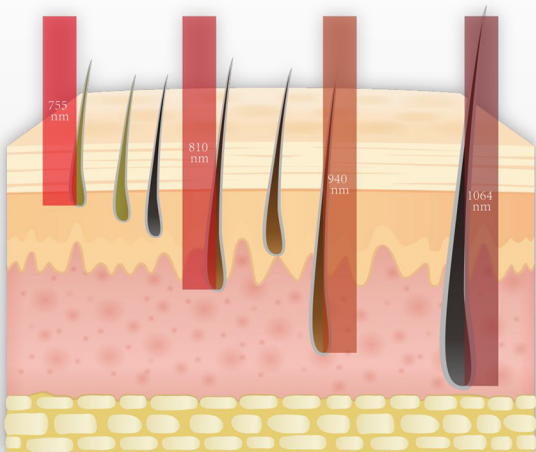

755nm: Maximum melanin absorption and shallow skin penetration. Perfect for thin and/or light hair and for hair whose root structure is not deep.

808nm: The "classic" wavelength for hair removal. Medium melanin absorption and deeper skin penetration than 755nm. Perfect for most regular thickness hair possessing average root depth and color.

940nm: Moderate melanin absorption and increased penetration. Perfect for dark hair whose roots are somewhat shallow.

1064nm: Lower melanin absorption combines with the deepest penetration. Ideal for all types of dark hair which is deeply rooted in areas such as the back, scalp, armpits and pubic area.

1200W · 10-100MS

1200W · 10-100MS

Super High Power
Super Long Life Span
Super Short pulse Duration

755nm
808nm
940nm
1064nm



Introduction

10.4 inch multi color touch screen



1200W Treatment head



ABS material case



360-degree silent wheel



Treatment head Advantage

Spot size: 12mm*12mm

Silicone safe button

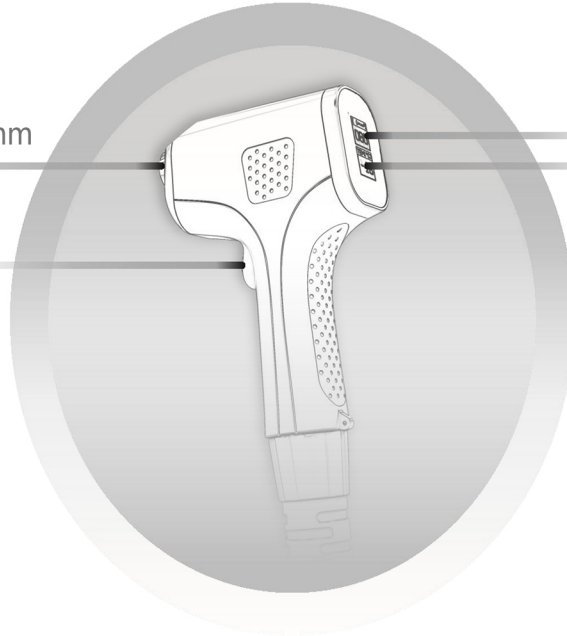

Fluence: 10-80 J / cm²

Treatment head temperature: Max -16 °C

Output power : 1200W (100W per bar)

Bars : USA imported laser bar

1200W laser-high peak power

Treatment head Advantage

Treatment head Advantage

Notice:

Turn on the machine and prepare for 5 minutes



Infrared Thermometer
Display minus 16.5 degrees

screen display
Minus 16 degrees

Internal structure

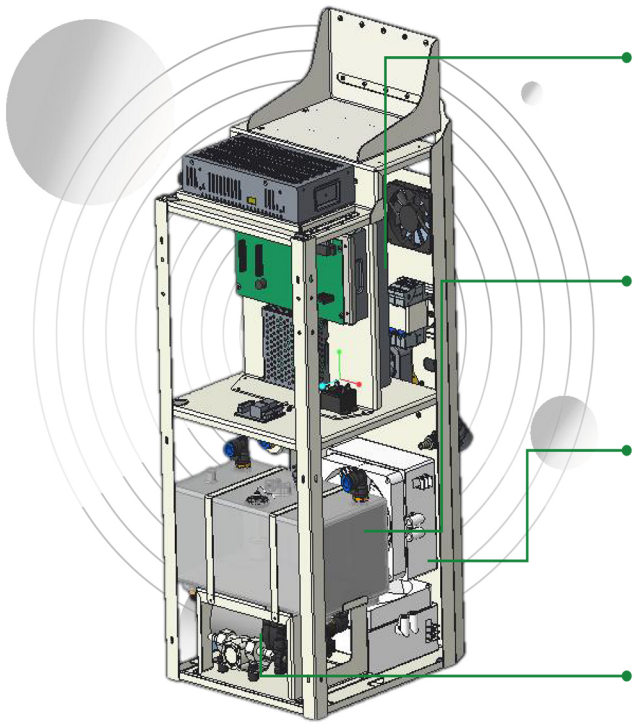

Power source

Low output current ripple and high stability;
Constant frequency adjustment to achieve high-precision constant current output;



Integrated water tank

Volume 5L-water quality is guaranteed
Fast water circulation, constant temperature and guaranteed water quality, which can ensure the long-term use and work of the instrument.

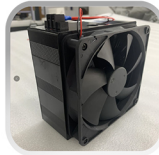

Thermal- electric refrigeration system

Power: 120W

Advantages: The constant temperature refrigeration module keeps the water temperature at about 20-25 degrees, which can ensure the continuous operation of the instrument.



German imported water pump

Circulating water flow rate is 5L / min-fast water circulation

Specifications

Laser type	High Intensity Diode Laser
Laser Handle Output Power	1200W
Total Power	3000W
Wavelength	755nm 808nm 940nm1064nm
Shots Guarantee	1 years no limited
Fluence	10~80J/cm2
Pulse width	10-100ms
Spot size	12mm*12mm
Frequency	1~10Hz
Treatment head temperatur	Max -16 °C
Cooling System	Constant temperature refrigeration 25 degree
Display	10.4 Inch multi color screen
Package size	82*55*120CM
Gross Weight	82Kg



Technology Advantage

- USA Imported coherent laser bar is more stable. And 1200W high power output laser energy can achieve the best hair removal.
- Low investment and high return. The treatment head is guaranteed for 2 years with No limitation
- The constant temperature refrigeration module keeps the water temperature at about 20-25 degrees, which can ensure the system to work continuously for 48 hours without stop.
- Using advanced TEC and sapphire contact cooling technology, the terminal temperature is controlled under -16°C , and the skin is properly cooled during the hair removal process, while ensuring the possibility of zero frostbite.
- The frequency reaches 10hz, the treatment is more fast.
- 808nm wavelength laser targeted the destruction of hair follicle pigments.



Technology Advantage

- 10-100ms pulse duration to ensure painless destruction of hair follicles
- The diode laser permanently destroys the hair follicles, and the remaining hair will be very small without affecting the appearance.
- The treatment head display screen displays the cooling temperature accordingly, making the operation more convenient.
- Super-light handle to reduce the difficulty of the operator's work and increase the experience value
- Normal mode and fast mode are optional, fast hair removal can also save 5 commonly used parameters, convenient and fast
- Spiral boost connector, you can insert the treatment head easily



Technology Advantage

Treats all hair colors from black hair to light color hair

Treats all skin types from white to the dark skin

No pain; short treatment sessions

Effective, safe treatment for permanent hair removal



Technology Advantage

01

Shave the hair from the treatment area (retain 1-2mm)



02

Clean the treatment area



03

Apply cold gel



04

Operator puts on goggles



Technology Advantage

05

Customers put on Eyegoogle



06

Adjust parameters for treatment



07

After treatment, clean the treatment site to avoid folliculitis



08

Clean the treatment head



Before



After

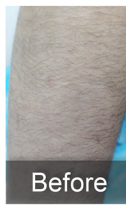

Before

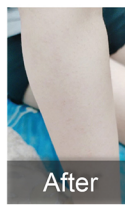

After

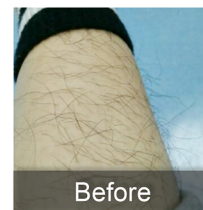

Before



After



Before



After



Before - After